

FEATURES 2

PICTORIAL VIEW 3

FIXED FRAMING DETAILS 4

MISCELLANEOUS DETAILS 5

WINDLOAD / DEADLOAD CHARTS 6, 7

THERMAL CHARTS 8-20

Laws and building and safety codes governing the design and use of Kawneer products, such as glazed entrance, window, and curtain wall products, vary widely. Kawneer does not control the selection of product configurations, operating hardware, or glazing materials, and assumes no responsibility therefor.

Kawneer reserves the right to change configuration without prior notice when deemed necessary for product improvement.
© 2010, Kawneer Company, Inc.

Metric (SI) conversion figures are included throughout these details for reference. Numbers in parentheses () are millimeters unless otherwise noted.

The following metric (SI) units are found in these details:

- m – meter
- cm – centimeter
- mm – millimeter
- s – second
- Pa – pascal
- MPa – megapascal

Features

- 24mm IsoWeb® glass-reinforced nylon 6/6 thermal break provides:
 - Improved condensation resistance and thermal transmittance performance capability
 - Rigid profiles with composite structural performance
 - Exterior / interior finish options
- Meets or exceeds the highest performance levels of CSA standard CAN/CSA-A440 Windows
- Vented and drained rain screen glazing cavity
- Coped joinery with screw spline fastening
- Recessed interior leg on perimeter section to accept air and / or vapour barrier membranes
- Glazing flanges on same plane providing flush appearance
- Accommodates 25mm and 44mm sealed unit thicknesses
- Glass installed and replaced from interior
- Tremco® VISIONstrip® exterior glazing system
- EPDM rubber air seal gasket along perimeter of 25mm sealed unit
- EPDM rubber interior gasket pre-loaded to snap-in glass stop
- Accepts 512 Ventrow Thermal Ventilator inserts

Laws and building and safety codes governing the design and use of Kawneer products, such as glazed entrance, window, and curtain wall products, vary widely. Kawneer does not control the selection of product configurations, operating hardware, or glazing materials, and assumes no responsibility therefor.

Kawneer reserves the right to change configuration without prior notice when deemed necessary for product improvement.
© 2010, Kawneer Company, Inc.

Laws and building and safety codes governing the design and use of Kawneer products, such as glazed entrance, window, and curtain wall products, vary widely. Kawneer does not control the selection of product configurations, operating hardware, or glazing materials, and assumes no responsibility therefor.

Kawneer reserves the right to change configuration without prior notice when deemed necessary for product improvement.
© 2010, Kawneer Company, Inc.

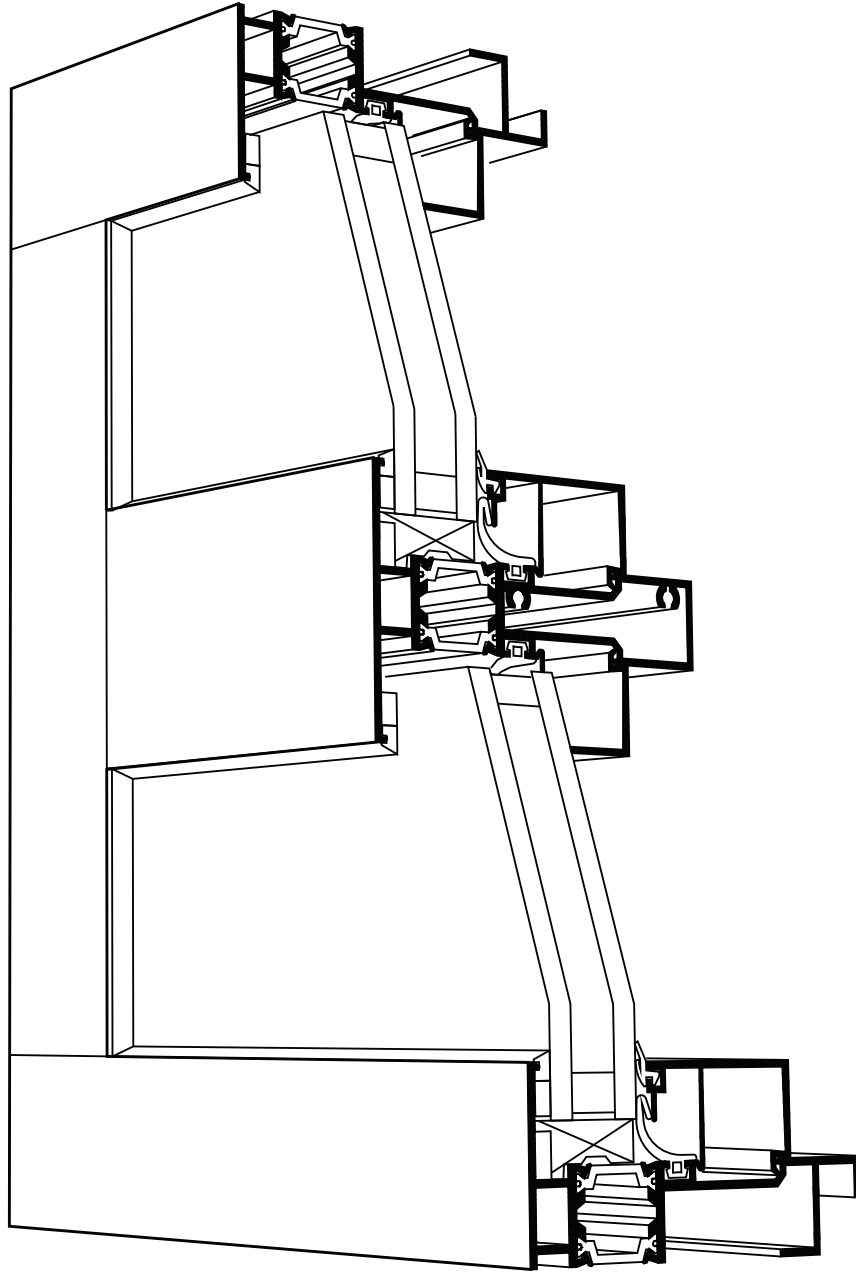

Additional information and CAD details are available at www.kawneer.com

PUNCHED OPENING WITH VERTICALS

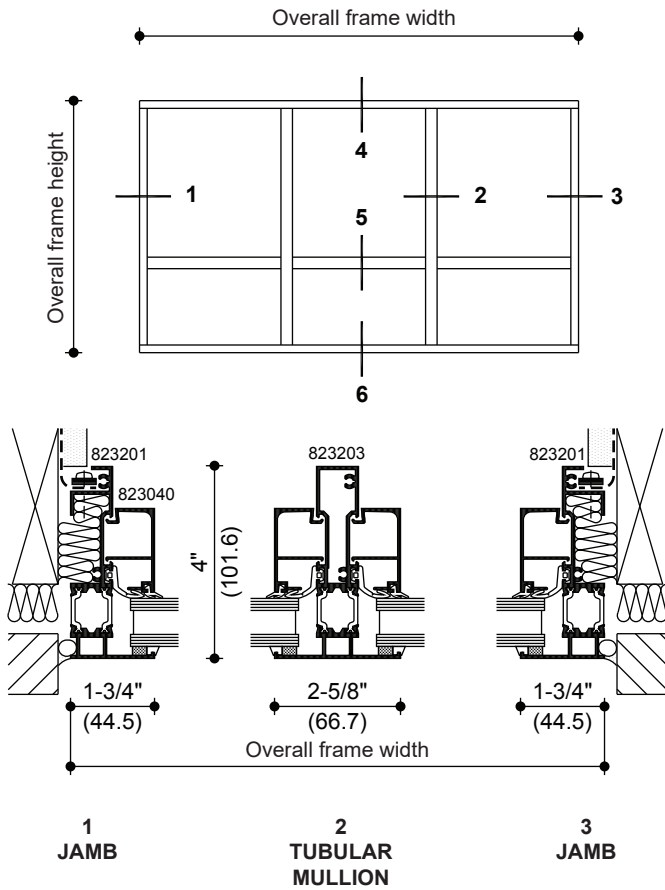

MULTI-MODULAR STRIP WINDOW

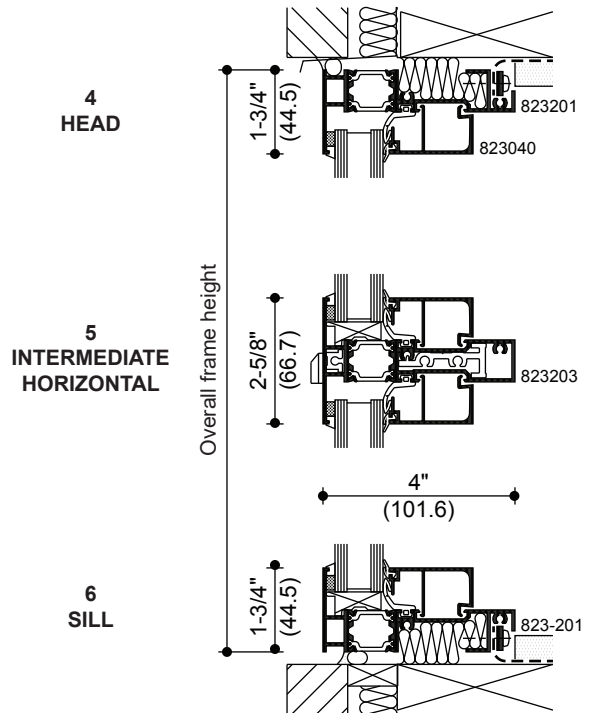
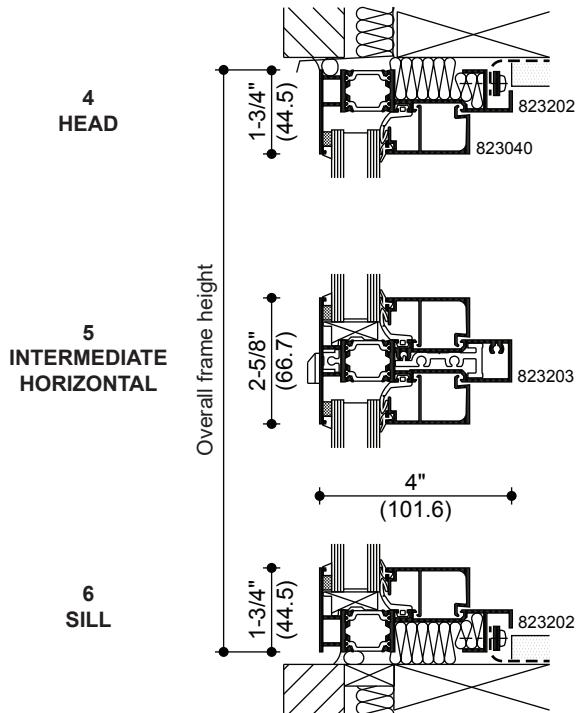
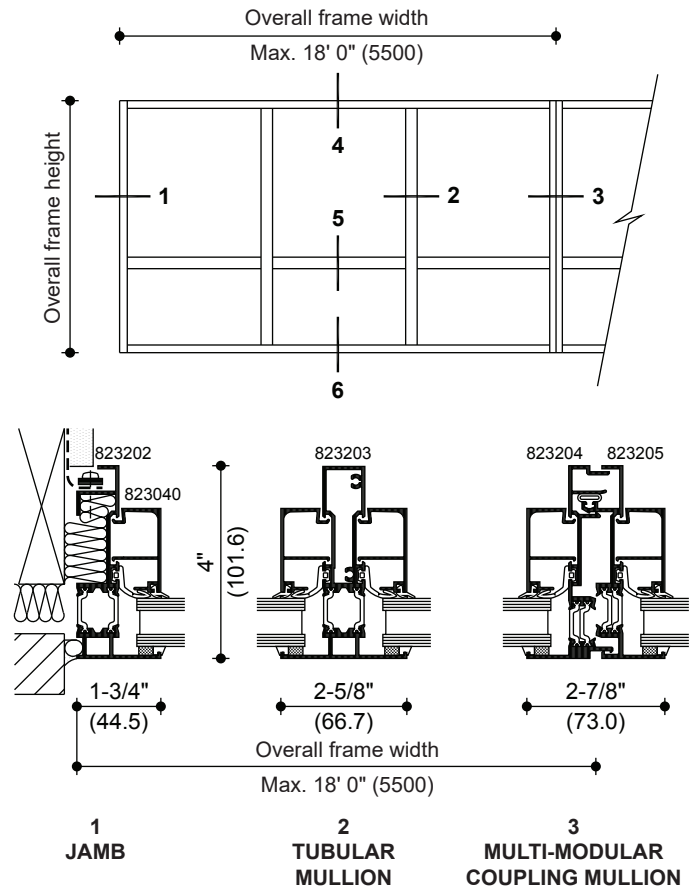

Laws and building and safety codes governing the design and use of Kawneer products, such as glazed entrance, window, and curtain wall products, vary widely. Kawneer does not control the selection of product configurations, operating hardware, or glazing materials, and assumes no responsibility therefor.

Kawneer reserves the right to change configuration without prior notice when deemed necessary for product improvement.
© 2010, Kawneer Company, Inc.

Additional information and CAD details are available at www.kawneer.com

TRIPLE GLAZED
[ACCEPTS 1-3/4" (44) SEALED UNITS]

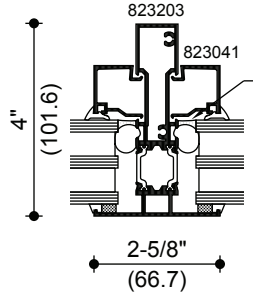

DEFLECTION HEAD
[ALLOWS ± 5/8" (15.9) MOVEMENT]

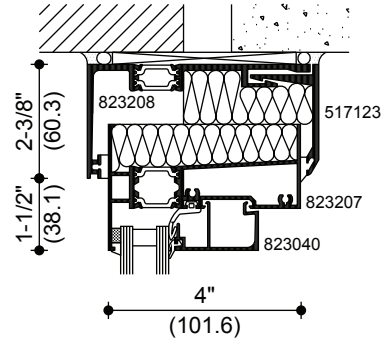

90° INSIDE CORNER

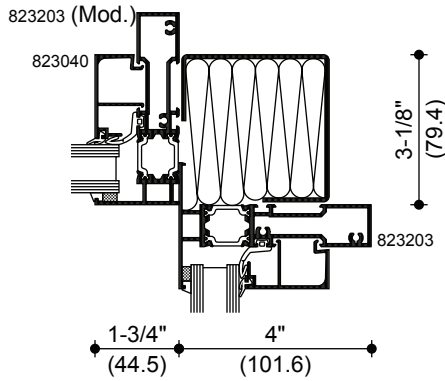

90° OUTSIDE CORNER

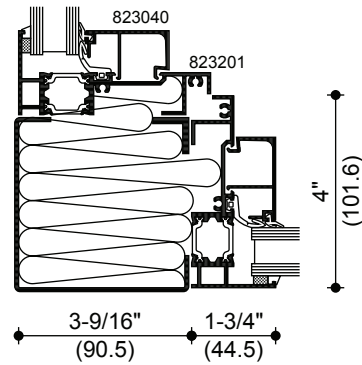

TYPICAL SILL DETAILS

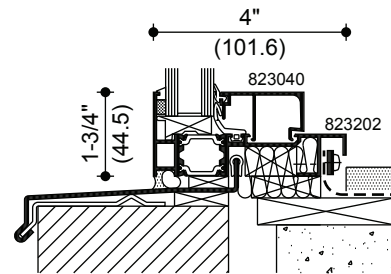
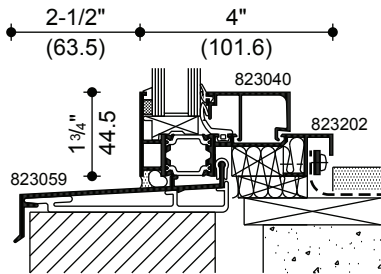

Laws and building and safety codes governing the design and use of Kawneer products, such as glazed entrance, window, and curtain wall products, vary widely. Kawneer does not control the selection of product configurations, operating hardware, or glazing materials, and assumes no responsibility therefor.

Kawneer reserves the right to change configuration without prior notice when deemed necessary for product improvement.
© 2010, Kawneer Company, Inc.

WIND LOAD CHARTS

Mullions are designed for deflection limitations in accordance with AAMA TIR-A11 of L/175 up to 13' 6" and L/240 +1/4" above 13' 6". These curves are for mullions WITH HORIZONTALS and are based on engineering calculations for stress and deflection. Allowable wind load stress for ALUMINUM 15,152 psi (104MPa), STEEL 30,000 psi (207MPa). Charted curves, in all cases are for the limiting value. Wind load charts contained herein are based upon nominal wind load utilized in allowable stress design. A conversion from Load Resistance Factor Design (LRFD) is provided. To convert ultimate wind loads to nominal loads, multiply ultimate wind loads by a factor of 0.6 per ASCE/SEI 7. A 4/3 increase in allowable stress has not been used to develop these curves. For special situations not covered by these curves, contact your Kawneer representative for additional information.

DEADLOAD CHARTS

Horizontal or deadload limitations are based upon 1/16" (1.6) at operable vents or 1/8" (3.2) at fixed openings, maximum allowable deflection at the center of an intermediate horizontal member. The accompanying charts are calculated for 1" (25.4) thick insulating glass supported on two setting blocks placed at the loading points shown.

Laws and building and safety codes governing the design and use of Kawneer products, such as glazed entrance, window, and curtain wall products, vary widely. Kawneer does not control the selection of product configurations, operating hardware, or glazing materials, and assumes no responsibility therefor.

Kawneer reserves the right to change configuration without prior notice when deemed necessary for product improvement.
© 2010, Kawneer Company, Inc.

WINDLOAD LIMITATIONS

	Allowable Stress Design Load	LRFD Ultimate Design Load
A =	15 PSF (720)	25 PSF (1200)
B =	20 PSF (960)	33 PSF (1580)
C =	25 PSF (1200)	42 PSF (2000)
D =	30 PSF (1440)	50 PSF (2400)
E =	40 PSF (1920)	67 PSF (3200)

WITH HORIZONTALS

MULLION CENTERS IN METERS

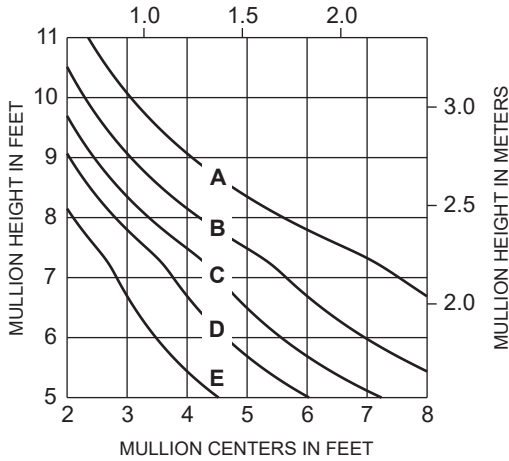

WITHOUT HORIZONTALS

MULLION CENTERS IN METERS

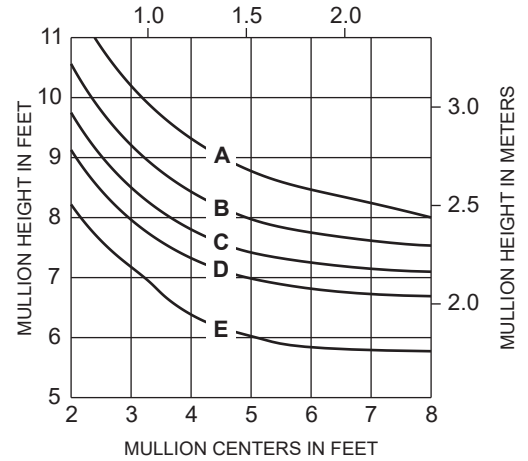

WITH HORIZONTALS

MULLION CENTERS IN METERS

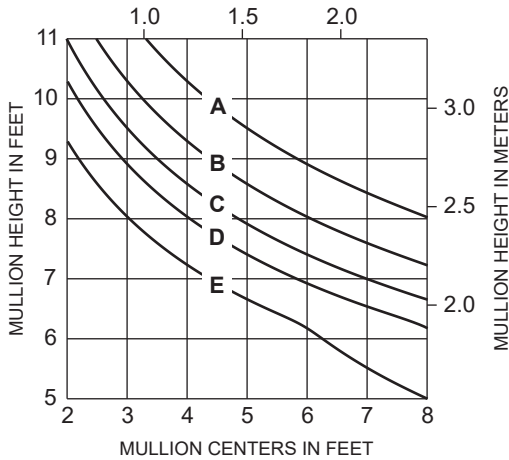

WITHOUT HORIZONTALS

MULLION CENTERS IN METERS

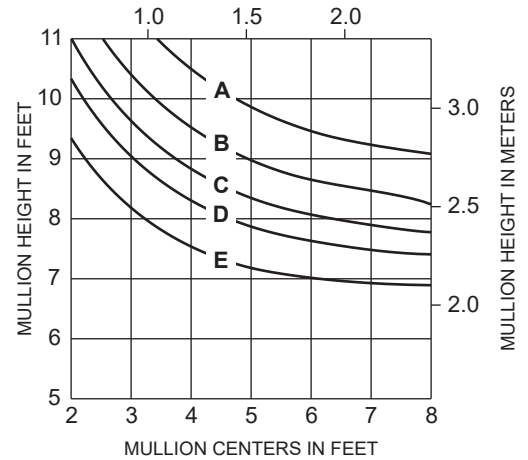

DEADLOAD LIMITATIONS

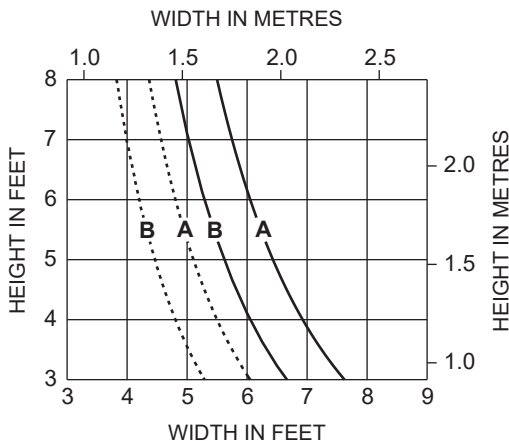

..... Intermediate Horizontal Over Ventilator (Maximum Deflection 1/16")
 — Intermediate Horizontal Over Fixed Lite (Maximum Deflection 1/8")

Curves are for sealed units with setting blocks 3" (76 mm) from the ends of the lite.

Intermediate Horizontal 823203

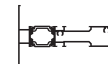

I = 0.17 in⁴ (7.20 x 10⁴ mm⁴)
 S = 0.20 in³ (0.32 x 10⁴ mm³)

A - Double glazed seal unit with (2) 6mm lites.

B - Triple glazed sealed unit with (3) 6mm lites.

Laws and building and safety codes governing the design and use of Kawneer products, such as glazed entrance, window, and curtain wall products, vary widely. Kawneer does not control the selection of product configurations, operating hardware, or glazing materials, and assumes no responsibility therefor.

Kawneer reserves the right to change configuration without prior notice when deemed necessary for product improvement.

© 2010, Kawneer Company, Inc.

Generic Project Specific U-factor Example Calculation
 (Percent of Glass will vary on specific products depending on sitelines)

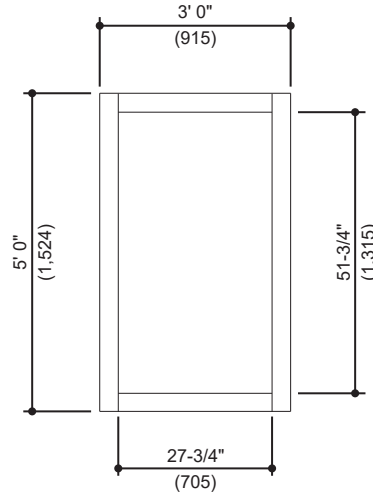

Example Glass U-Factor = 0.42 Btu/hr • ft² • °F

Total Daylight Opening = 27-3/4" • 51-3/4" = 9.97ft²

Total Projected Area = 3' 0" • 5' 0" = 15 ft²

Percent of Glass = (Total Daylight Opening ÷ Total Projected Area)100
 = (9.97 ÷ 15)100 = 66%

System U-factor vs Percent of Glass Area

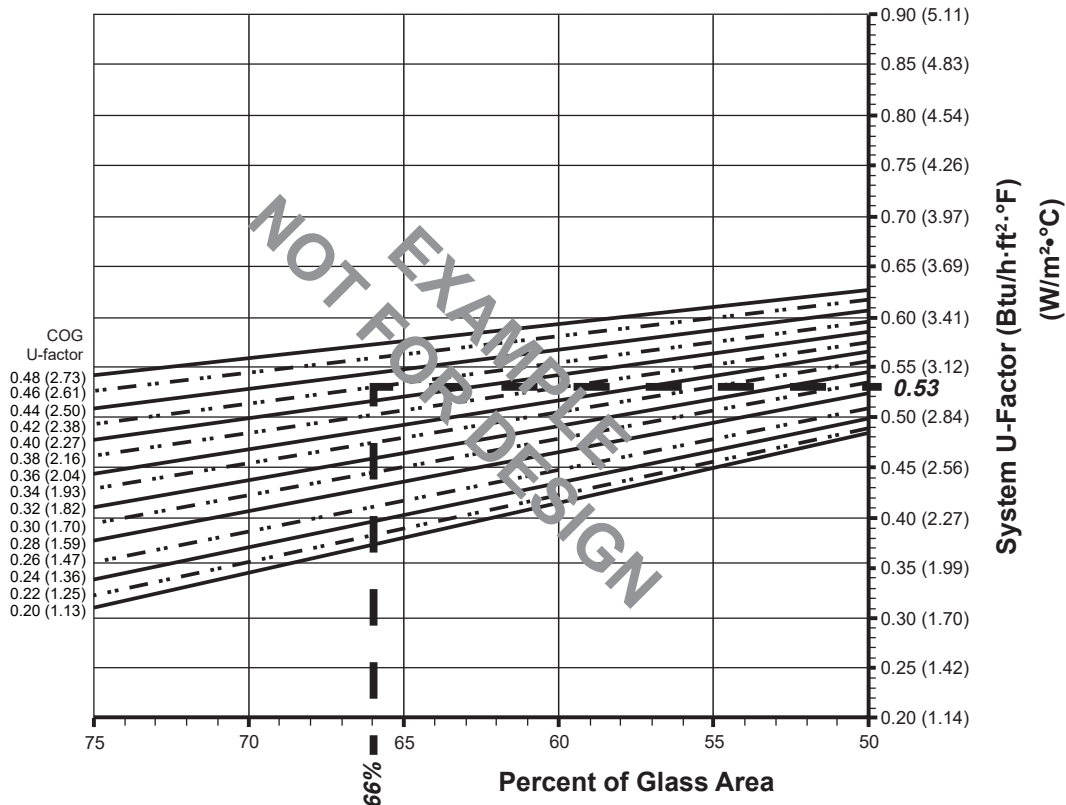

Based on 66% glass and center of glass (COG) U-factor of 0.42
 System U-factor is equal to 0.53 Btu/hr • ft² • °F

Laws and building and safety codes governing the design and use of Kawneer products, such as glazed entrance, window, and curtain wall products, vary widely. Kawneer does not control the selection of product configurations, operating hardware, or glazing materials, and assumes no responsibility therefor.

Kawneer reserves the right to change configuration without prior notice when deemed necessary for product improvement.
 © 2010, Kawneer Company, Inc.

FIXED WINDOW WITH 1" DOUBLE GLAZING
Warm-Edge Glazing Spacer

Note:

Values in parentheses are metric.
 COG = Center of Glass.
 Charts are generated per AAMA 507

System U-factor vs Percent of Glass Area

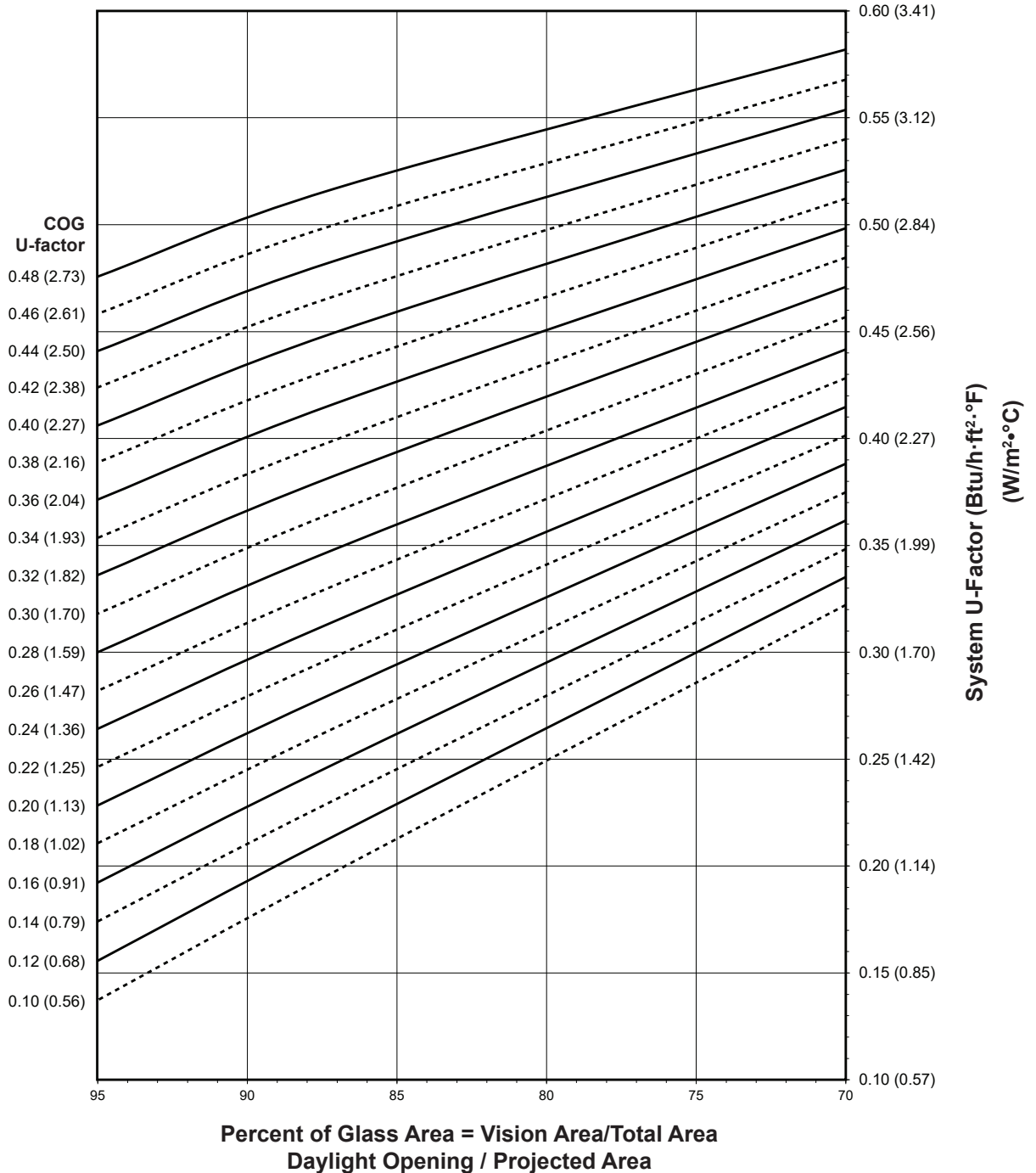

Notes for System U-factor, SHGC and VT charts:

For glass values that are not listed, linear interpolation is permitted.
 Glass properties are based on center of glass values and are obtained from your glass supplier.

Laws and building and safety codes governing the design and use of Kawneer products, such as glazed entrance, window, and curtain wall products, vary widely. Kawneer does not control the selection of product configurations, operating hardware, or glazing materials, and assumes no responsibility therefor.

Kawneer reserves the right to change configuration without prior notice when deemed necessary for product improvement.
 © 2010, Kawneer Company, Inc.

FIXED WINDOW WITH 1" DOUBLE GLAZING
Warm-Edge Glazing Spacer

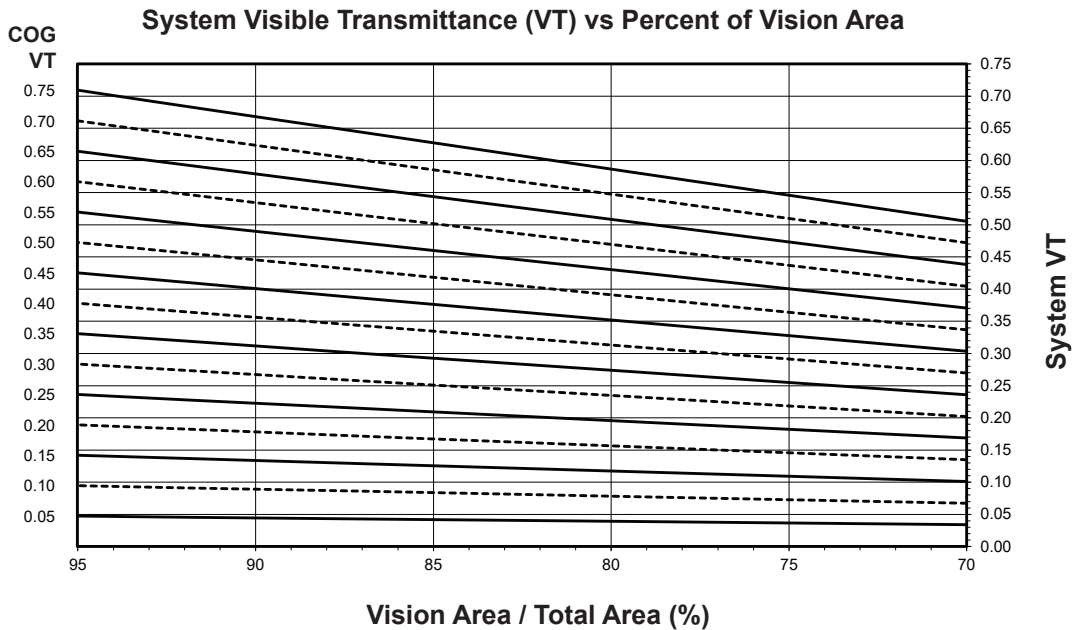
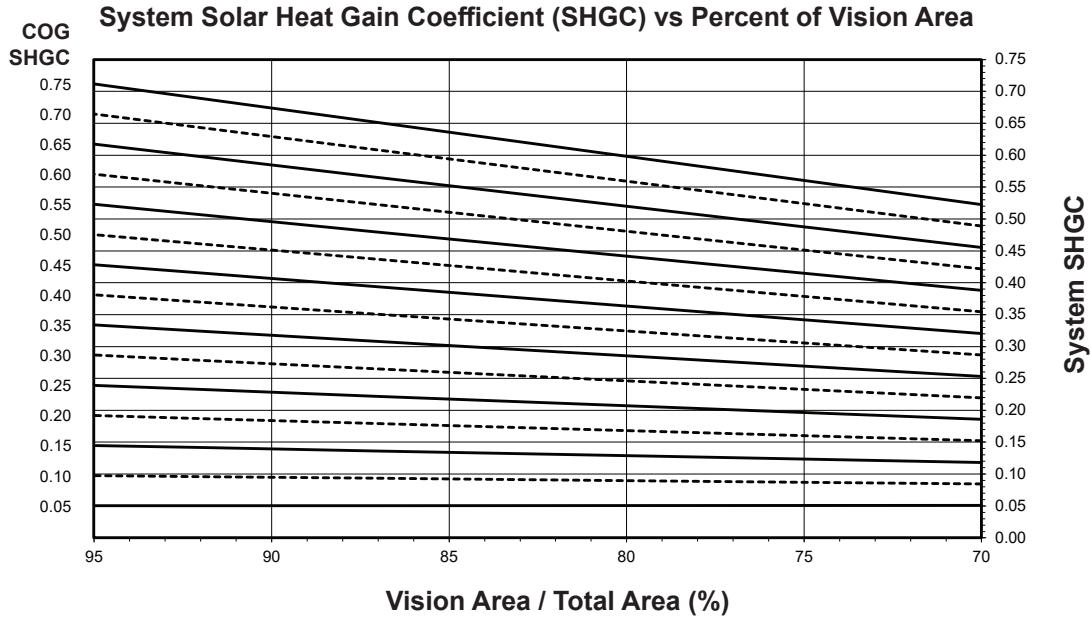

Laws and building and safety codes governing the design and use of Kawneer products, such as glazed entrance, window, and curtain wall products, vary widely. Kawneer does not control the selection of product configurations, operating hardware, or glazing materials, and assumes no responsibility therefor.

Kawneer reserves the right to change configuration without prior notice when deemed necessary for product improvement.
 © 2010, Kawneer Company, Inc.

Thermal Transmittance ¹ (BTU/hr • ft ² • °F)

Glass U-Factor ³	Overall U-Factor ⁴
0.48	0.52
0.46	0.50
0.44	0.48
0.42	0.47
0.40	0.45
0.38	0.43
0.36	0.42
0.34	0.40
0.32	0.38
0.30	0.37
0.28	0.35
0.26	0.33
0.24	0.31
0.22	0.30
0.20	0.28
0.18	0.26
0.16	0.25
0.14	0.23
0.12	0.21
0.10	0.20

**FIXED WINDOW WITH
1" DOUBLE GLAZING
Warm-Edge Glazing Spacer**

NOTE: For glass values that are not listed, linear interpolation is permitted.

1. U-Factors are determined in accordance with NFRC 100.
2. SHGC and VT values are determined in accordance with NFRC 200.
3. Glass properties are based on center of glass values and are obtained from your glass supplier.
4. Overall U-Factor, SHGC, and VT Matricies are based on the standard NFRC specimen size of 1,200 mm wide by 1,500 mm high (47-1/4" by 59-1/16").

SHGC Matrix ²

Glass SHGC ³	Overall SHGC ⁴
0.75	0.65
0.70	0.61
0.65	0.57
0.60	0.52
0.55	0.48
0.50	0.44
0.45	0.39
0.40	0.35
0.35	0.31
0.30	0.27
0.25	0.22
0.20	0.18
0.15	0.14
0.10	0.09
0.05	0.05

Visible Transmittance ²

Glass VT ³	Overall VT ⁴
0.75	0.64
0.70	0.60
0.65	0.56
0.60	0.52
0.55	0.47
0.50	0.43
0.45	0.39
0.40	0.34
0.35	0.30
0.30	0.26
0.25	0.21
0.20	0.17
0.15	0.13
0.10	0.09
0.05	0.04

Laws and building and safety codes governing the design and use of Kawneer products, such as glazed entrance, window, and curtain wall products, vary widely. Kawneer does not control the selection of product configurations, operating hardware, or glazing materials, and assumes no responsibility therefor.

Kawneer reserves the right to change configuration without prior notice when deemed necessary for product improvement.
© 2010, Kawneer Company, Inc.

FIXED WINDOW WITH 1" DOUBLE GLAZING
Aluminum Glazing Spacer

Note:

Values in parentheses are metric.
 COG = Center of Glass.
 Charts are generated per AAMA 507

System U-factor vs Percent of Glass Area

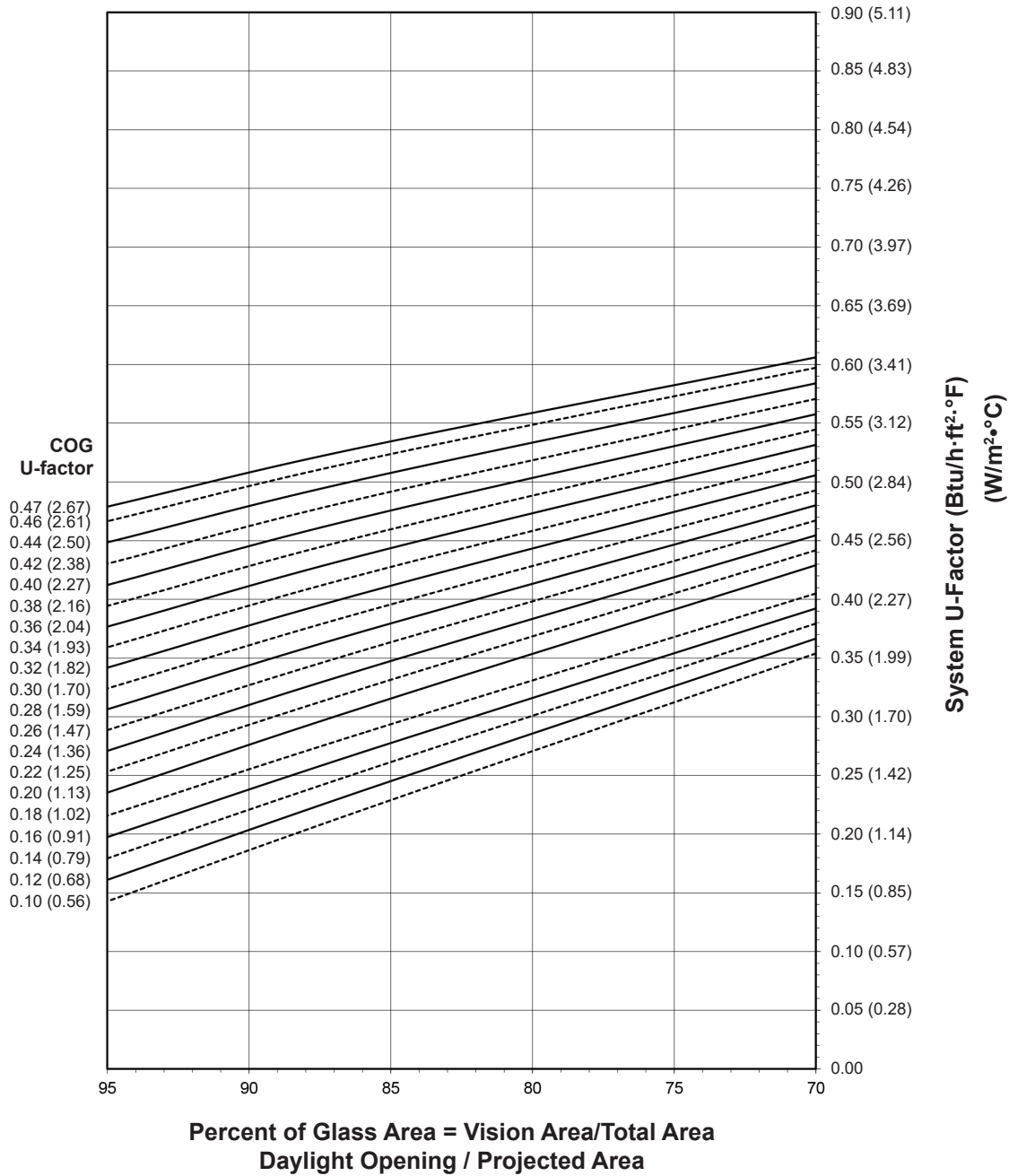

Notes for System U-factor, SHGC and VT charts:
 For glass values that are not listed, linear interpolation is permitted.
 Glass properties are based on center of glass values and are obtained from your glass supplier.

Laws and building and safety codes governing the design and use of Kawneer products, such as glazed entrance, window, and curtain wall products, vary widely. Kawneer does not control the selection of product configurations, operating hardware, or glazing materials, and assumes no responsibility therefor.

Kawneer reserves the right to change configuration without prior notice when deemed necessary for product improvement.
 © 2010, Kawneer Company, Inc.

FIXED WINDOW WITH 1" DOUBLE GLAZING
Aluminum Glazing Spacer

System Solar Heat Gain Coefficient (SHGC) vs Percent of Vision Area

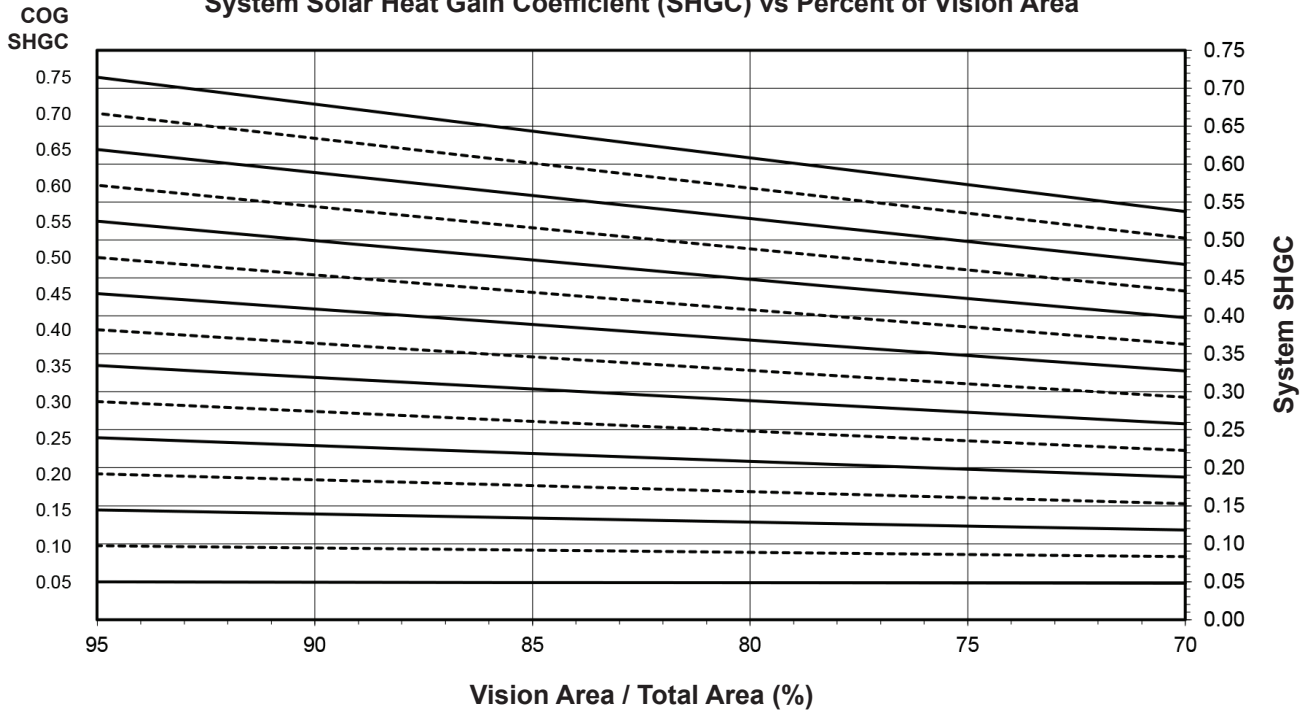

System Visible Transmittance (VT) vs Percent of Vision Area

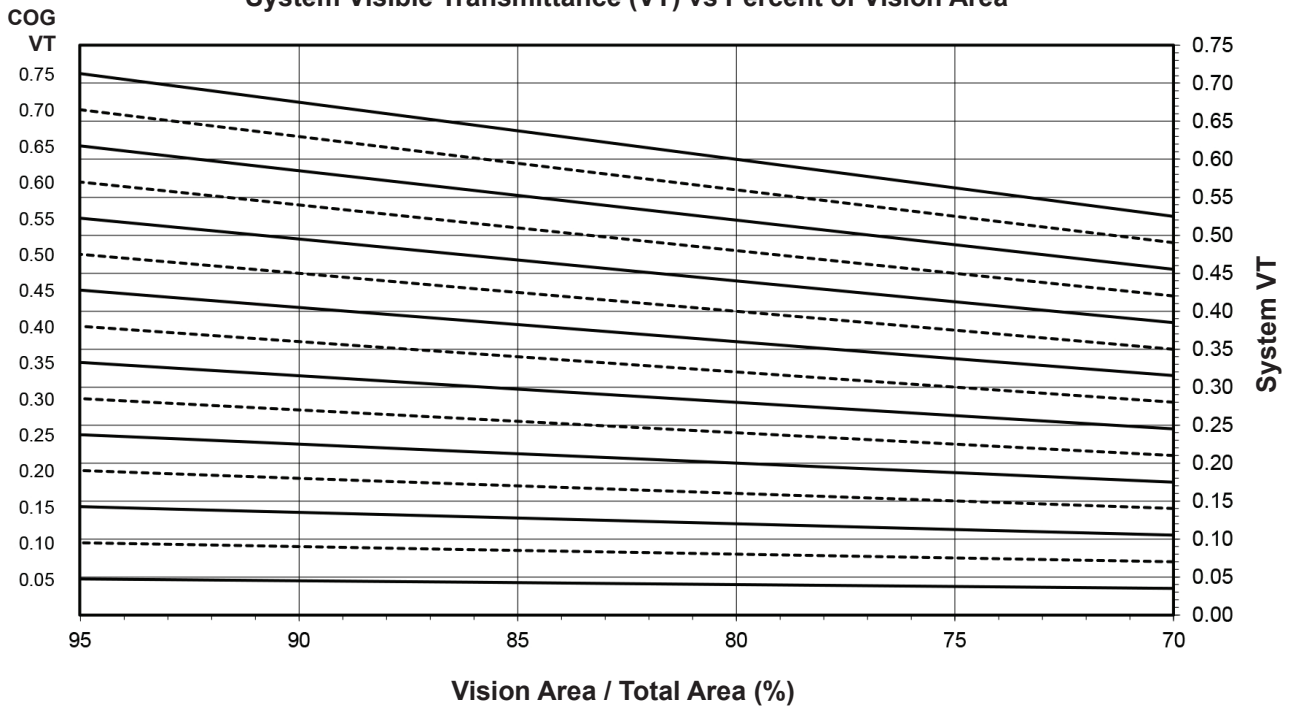

Laws and building and safety codes governing the design and use of Kawneer products, such as glazed entrance, window, and curtain wall products, vary widely. Kawneer does not control the selection of product configurations, operating hardware, or glazing materials, and assumes no responsibility therefor.

Kawneer reserves the right to change configuration without prior notice when deemed necessary for product improvement.
© 2010, Kawneer Company, Inc.

Thermal Transmittance ¹ (BTU/hr • ft² • °F)

Glass U-Factor ³	Overall U-Factor ⁴
0.48	0.53
0.46	0.52
0.44	0.50
0.42	0.49
0.40	0.47
0.38	0.45
0.36	0.44
0.34	0.42
0.32	0.41
0.30	0.39
0.28	0.37
0.26	0.36
0.24	0.34
0.22	0.32
0.20	0.31
0.18	0.29
0.16	0.27
0.14	0.25
0.12	0.24
0.10	0.22

**FIXED WINDOW WITH
1" DOUBLE GLAZING
Aluminum Glazing Spacer**

NOTE: For glass values that are not listed, linear interpolation is permitted.

1. U-Factors are determined in accordance with NFRC 100.
2. SHGC and VT values are determined in accordance with NFRC 200.
3. Glass properties are based on center of glass values and are obtained from your glass supplier.
4. Overall U-Factor, SHGC, and VT Matricies are based on the standard NFRC specimen size of 1,200 mm wide by 1,500 mm high (47-1/4" by 59-1/16").

SHGC Matrix ²

Glass SHGC ³	Overall SHGC ⁴
0.75	0.65
0.70	0.61
0.65	0.56
0.60	0.52
0.55	0.48
0.50	0.44
0.45	0.39
0.40	0.35
0.35	0.31
0.30	0.26
0.25	0.22
0.20	0.18
0.15	0.13
0.10	0.09
0.05	0.05

Visible Transmittance ²

Glass VT ³	Overall VT ⁴
0.75	0.64
0.70	0.60
0.65	0.56
0.60	0.52
0.55	0.47
0.50	0.43
0.45	0.39
0.40	0.34
0.35	0.30
0.30	0.26
0.25	0.21
0.20	0.17
0.15	0.13
0.10	0.09
0.05	0.04

Laws and building and safety codes governing the design and use of Kawneer products, such as glazed entrance, window, and curtain wall products, vary widely. Kawneer does not control the selection of product configurations, operating hardware, or glazing materials, and assumes no responsibility therefor.

Kawneer reserves the right to change configuration without prior notice when deemed necessary for product improvement.
© 2010, Kawneer Company, Inc.

FIXED WINDOW WITH 1-3/4" TRIPLE GLAZING

Warm-Edge Glazing Spacer

Note:

Values in parentheses are metric.
 COG = Center of Glass.
 Charts are generated per AAMA 507

System U-factor vs Percent of Glass Area

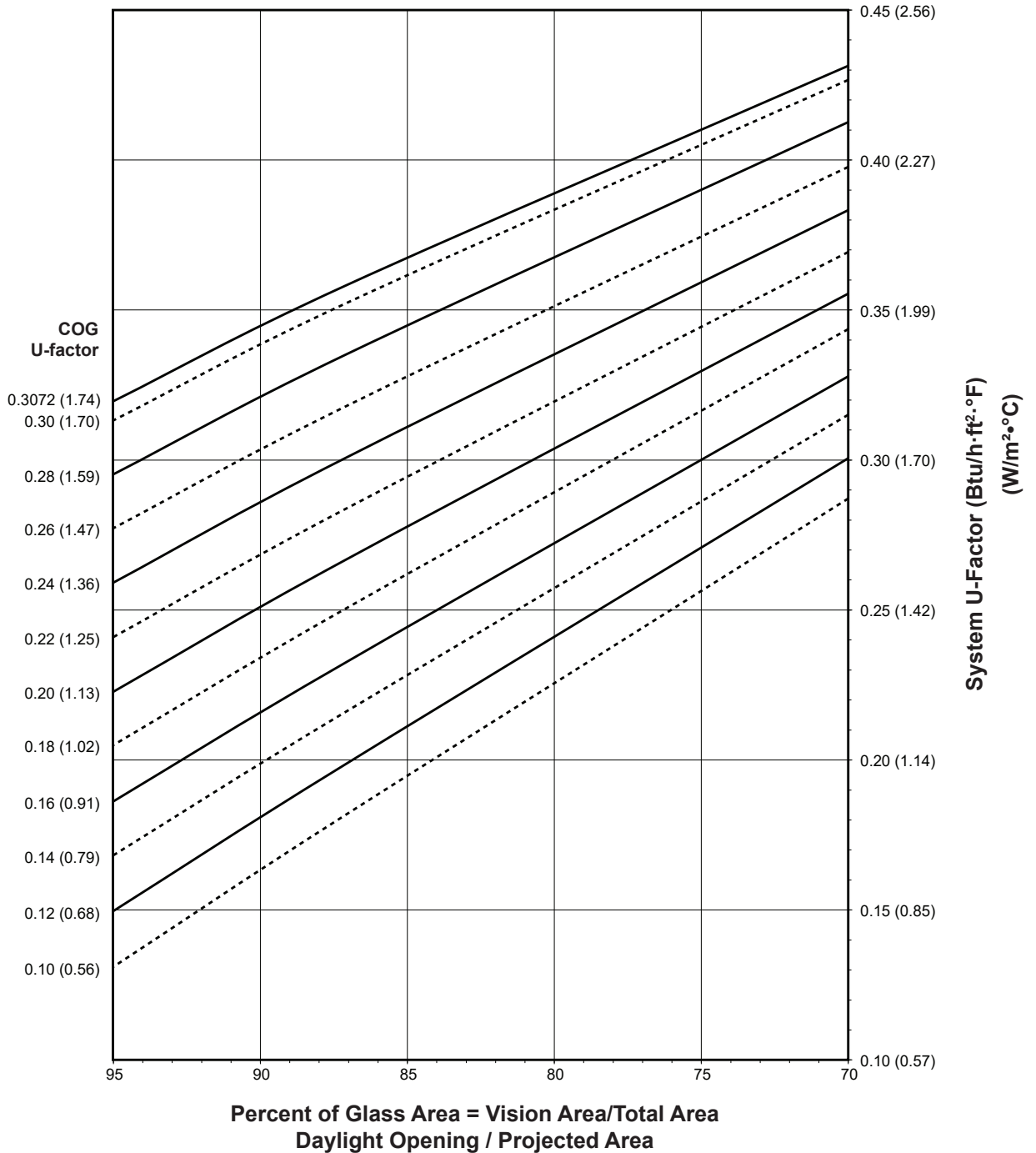

Notes for System U-factor, SHGC and VT charts:

For glass values that are not listed, linear interpolation is permitted.
 Glass properties are based on center of glass values and are obtained from your glass supplier.

Laws and building and safety codes governing the design and use of Kawneer products, such as glazed entrance, window, and curtain wall products, vary widely. Kawneer does not control the selection of product configurations, operating hardware, or glazing materials, and assumes no responsibility therefor.

Kawneer reserves the right to change configuration without prior notice when deemed necessary for product improvement.
 © 2010, Kawneer Company, Inc.

FIXED WINDOW WITH 1-3/4" TRIPLE GLAZING

Warm-Edge Glazing Spacer

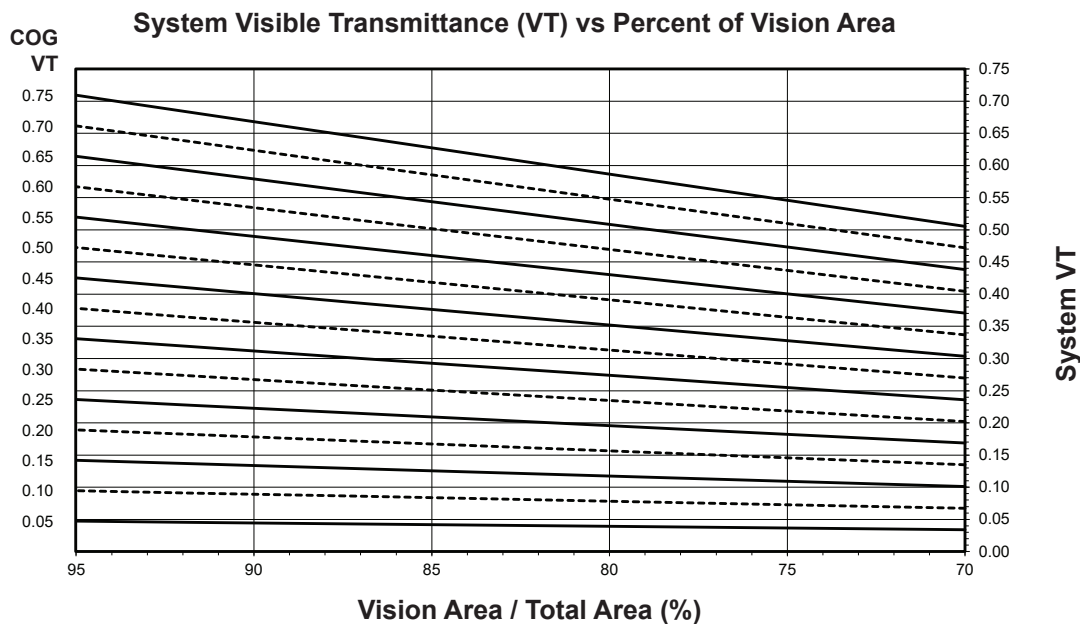
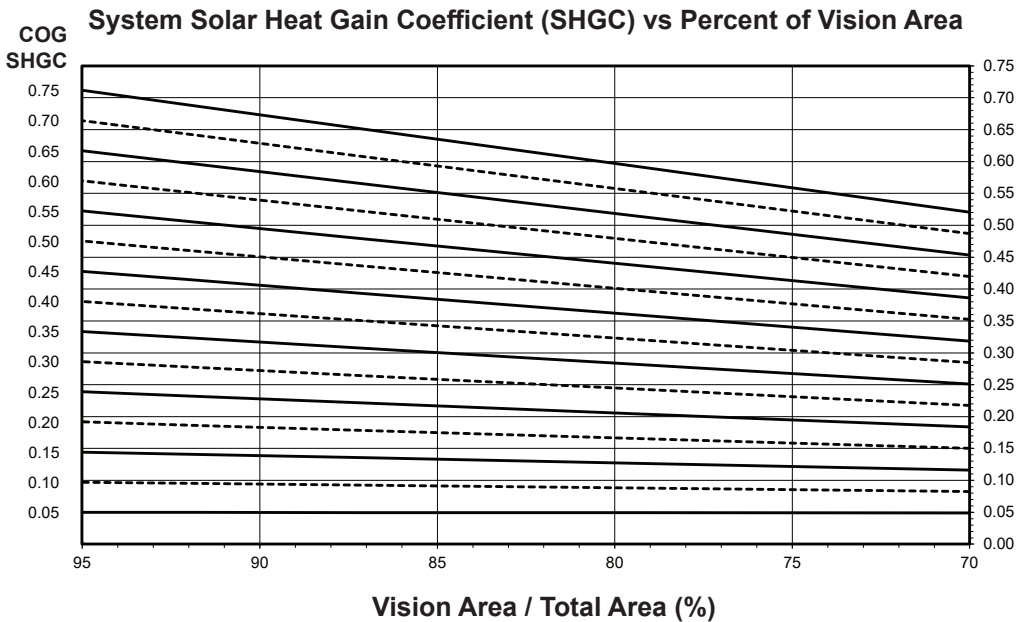

Laws and building and safety codes governing the design and use of Kawneer products, such as glazed entrance, window, and curtain wall products, vary widely. Kawneer does not control the selection of product configurations, operating hardware, or glazing materials, and assumes no responsibility therefor.

Kawneer reserves the right to change configuration without prior notice when deemed necessary for product improvement.
© 2010, Kawneer Company, Inc.

Thermal Transmittance ¹ (BTU/hr • ft ² • °F)

Glass U-Factor ³	Overall U-Factor ⁴
0.31	0.36
0.30	0.35
0.28	0.34
0.26	0.32
0.24	0.30
0.22	0.28
0.20	0.27
0.18	0.25
0.16	0.23
0.14	0.22
0.12	0.20
0.10	0.18

**FIXED WINDOW WITH
1-3/4" TRIPLE GLAZING
Warm-Edge Glazing Spacer**

NOTE: For glass values that are not listed, linear interpolation is permitted.

1. U-Factors are determined in accordance with NFRC 100.
2. SHGC and VT values are determined in accordance with NFRC 200.
3. Glass properties are based on center of glass values and are obtained from your glass supplier.
4. Overall U-Factor, SHGC, and VT Matricies are based on the standard NFRC specimen size of 1,200 mm wide by 1,500 mm high (47-1/4" by 59-1/16").

SHGC Matrix ²

Glass SHGC ³	Overall SHGC ⁴
0.75	0.65
0.70	0.61
0.65	0.57
0.60	0.52
0.55	0.48
0.50	0.44
0.45	0.39
0.40	0.35
0.35	0.31
0.30	0.26
0.25	0.22
0.20	0.18
0.15	0.14
0.10	0.09
0.05	0.05

Visible Transmittance ²

Glass VT ³	Overall VT ⁴
0.75	0.64
0.70	0.60
0.65	0.56
0.60	0.52
0.55	0.47
0.50	0.43
0.45	0.39
0.40	0.34
0.35	0.30
0.30	0.26
0.25	0.21
0.20	0.17
0.15	0.13
0.10	0.09
0.05	0.04

Laws and building and safety codes governing the design and use of Kawneer products, such as glazed entrance, window, and curtain wall products, vary widely. Kawneer does not control the selection of product configurations, operating hardware, or glazing materials, and assumes no responsibility therefor.

Kawneer reserves the right to change configuration without prior notice when deemed necessary for product improvement.
© 2010, Kawneer Company, Inc.

FIXED WINDOW WITH 1-3/4" TRIPLE GLAZING
Aluminum Glazing Spacer

Note:

Values in parentheses are metric.
 COG = Center of Glass.
 Charts are generated per AAMA 507

System U-factor vs Percent of Glass Area

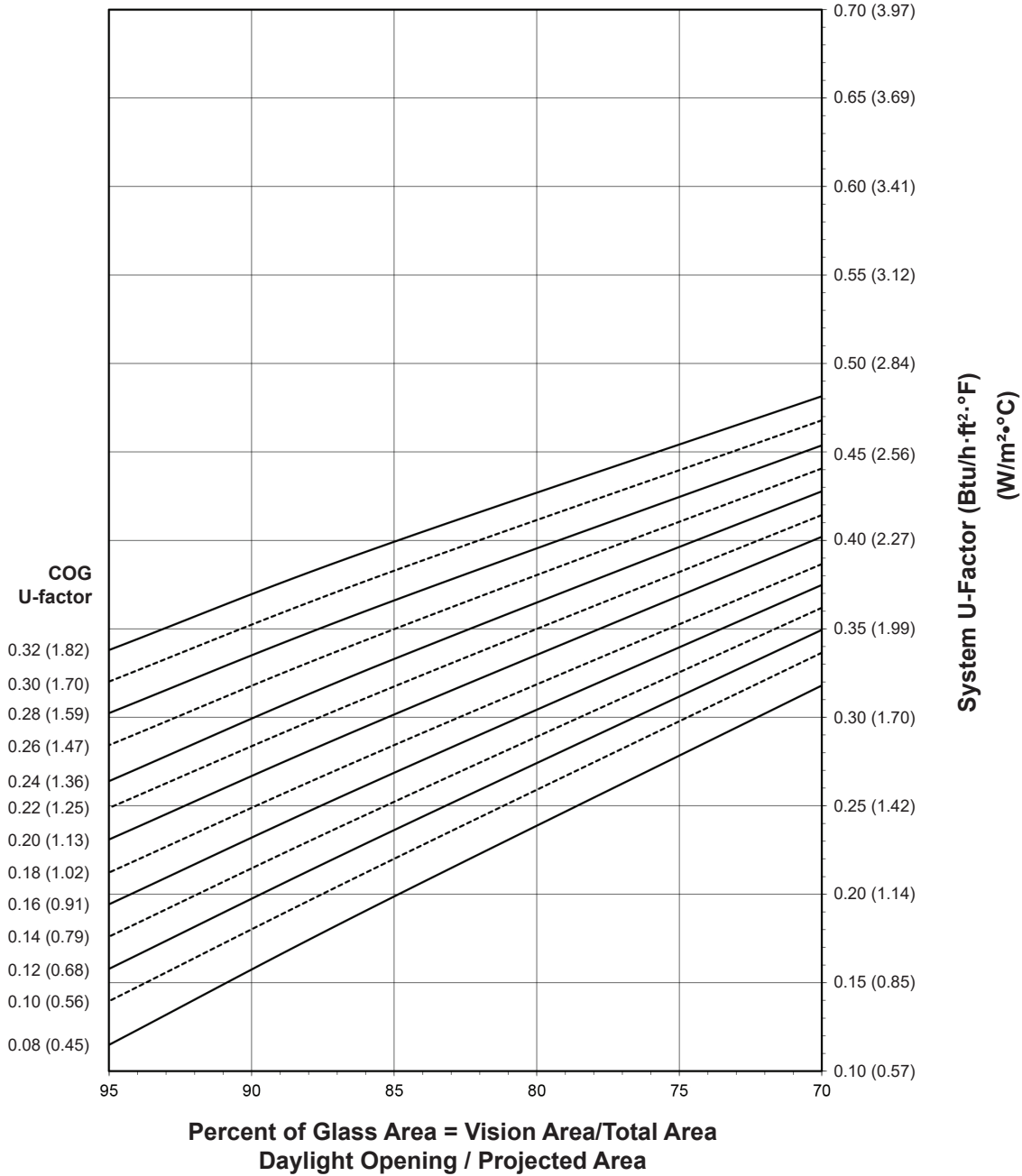

Notes for System U-factor, SHGC and VT charts:

For glass values that are not listed, linear interpolation is permitted.
 Glass properties are based on center of glass values and are obtained from your glass supplier.

Laws and building and safety codes governing the design and use of Kawneer products, such as glazed entrance, window, and curtain wall products, vary widely. Kawneer does not control the selection of product configurations, operating hardware, or glazing materials, and assumes no responsibility therefor.

Kawneer reserves the right to change configuration without prior notice when deemed necessary for product improvement.
 © 2010, Kawneer Company, Inc.

FIXED WINDOW WITH 1-3/4" TRIPLE GLAZING
Aluminum Glazing Spacer

System Solar Heat Gain Coefficient (SHGC) vs Percent of Vision Area

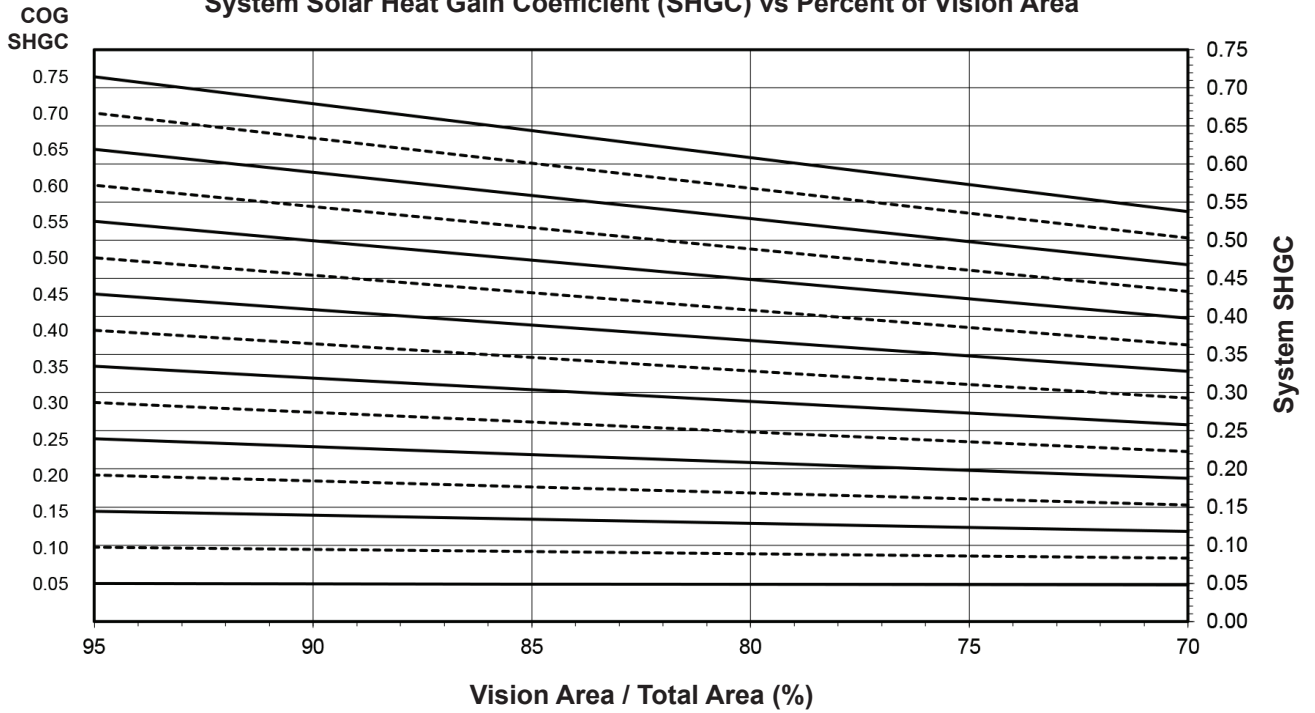

System Visible Transmittance (VT) vs Percent of Vision Area

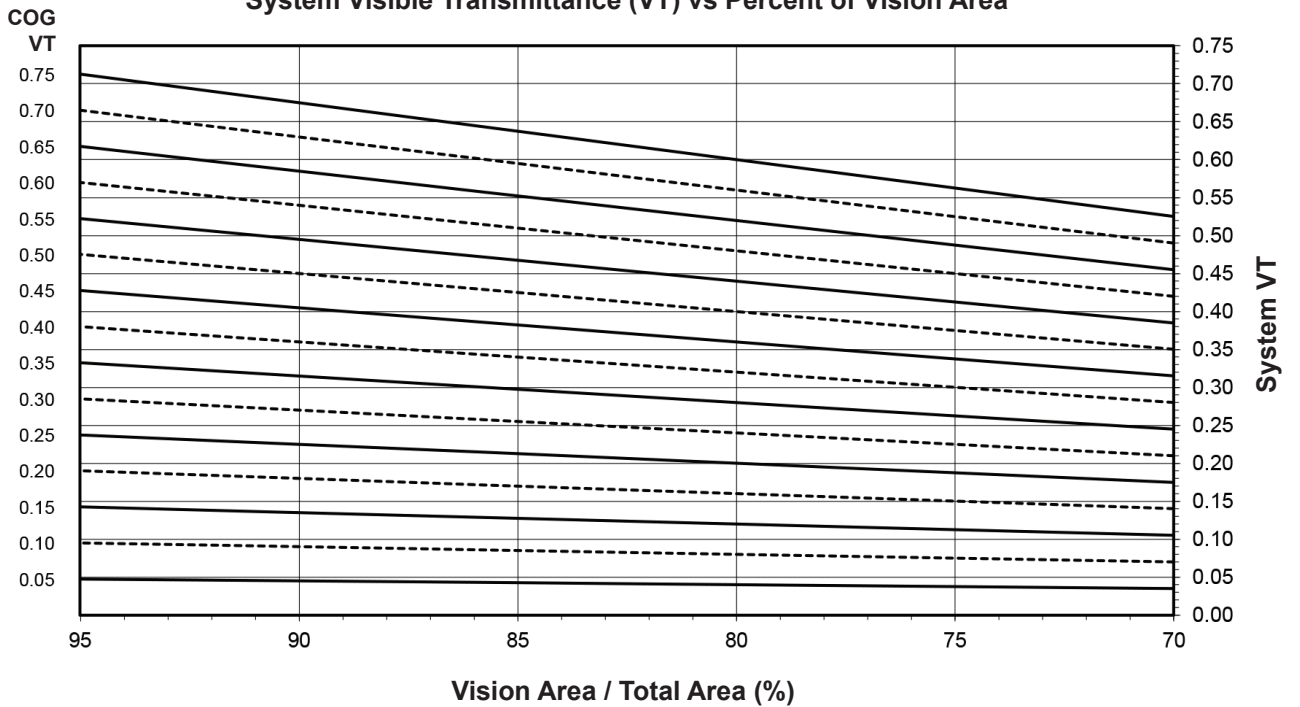

Laws and building and safety codes governing the design and use of Kawneer products, such as glazed entrance, window, and curtain wall products, vary widely. Kawneer does not control the selection of product configurations, operating hardware, or glazing materials, and assumes no responsibility therefor.

Kawneer reserves the right to change configuration without prior notice when deemed necessary for product improvement.
© 2010, Kawneer Company, Inc.

Thermal Transmittance¹ (BTU/hr • ft² • °F)

Glass U-Factor ³	Overall U-Factor ⁴
0.32	0.39
0.30	0.38
0.28	0.36
0.26	0.34
0.24	0.33
0.22	0.31
0.20	0.30
0.18	0.28
0.16	0.26
0.14	0.25
0.12	0.23
0.10	0.21
0.08	0.19

**FIXED WINDOW WITH
1-3/4" TRIPLE GLAZING
Aluminum Glazing Spacer**

NOTE: For glass values that are not listed, linear interpolation is permitted.

1. U-Factors are determined in accordance with NFRC 100.
2. SHGC and VT values are determined in accordance with NFRC 200.
3. Glass properties are based on center of glass values and are obtained from your glass supplier.
4. Overall U-Factor, SHGC, and VT Matricies are based on the standard NFRC specimen size of 1,200 mm wide by 1,500 mm high (47-1/4" by 59-1/16").

SHGC Matrix²

Glass SHGC ³	Overall SHGC ⁴
0.75	0.65
0.70	0.61
0.65	0.56
0.60	0.52
0.55	0.48
0.50	0.44
0.45	0.39
0.40	0.35
0.35	0.31
0.30	0.26
0.25	0.22
0.20	0.18
0.15	0.13
0.10	0.09
0.05	0.05

Visible Transmittance²

Glass VT ³	Overall VT ⁴
0.75	0.64
0.70	0.60
0.65	0.56
0.60	0.51
0.55	0.47
0.50	0.43
0.45	0.39
0.40	0.34
0.35	0.30
0.30	0.26
0.25	0.21
0.20	0.17
0.15	0.13
0.10	0.09
0.05	0.04

Laws and building and safety codes governing the design and use of Kawneer products, such as glazed entrance, window, and curtain wall products, vary widely. Kawneer does not control the selection of product configurations, operating hardware, or glazing materials, and assumes no responsibility therefor.

Kawneer reserves the right to change configuration without prior notice when deemed necessary for product improvement.
© 2010, Kawneer Company, Inc.